

GSM/WLAN Diplexer SSPD-113-149

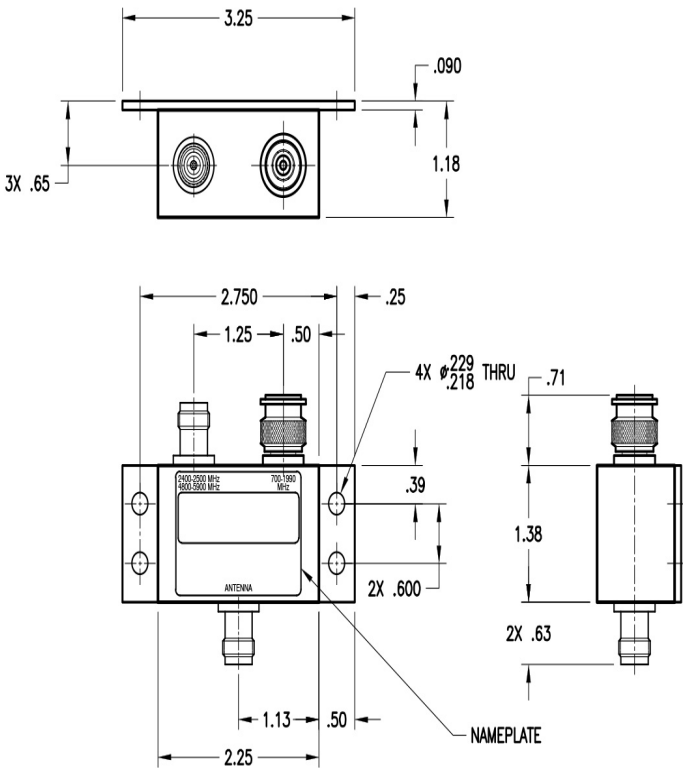

Please Note: For REFERENCE ONLY
Contact Sensor Systems for latest drawing

Description

SSPD-113-149: Diplexer operates at 850 to 1990, 3400 to 2500, and 4800-5900 MHz. The Diplexer allows simultaneous use of a single antenna between GSM and wireless LAN type devices.

The Diplexer exhibits very low insertion loss and has excellent isolation between frequency bands.

The SSPD-113-149 can be paired with Sensor System's telemetry and wireless antennas such as S65-5366-720.

FEDERAL & MILITARY SPECS: IEEE 802.11 A/B/G/N, GSM (GLOBAL SYSTEM FOR MOBILE COMMUNICATIONS), MIL-STD-810, MIL-HDBK-5400, MIL-E-5272.

Specifications

Electrical

Frequency	850-1990 MHz 2400-2500 MHz 4800-5900 MHz
VSWR	≤ 2.0:1
Impedance	50 Ω
Insertion Loss	1.0 dB Typical
Isolation	850-1850 MHz: >20.0 dB
	1850-1990 MHz: > 15.0 dB
	2400-2500 MHz: > 15.0 dB
	4800-5900 MHz: > 20.0 dB
Power	850-1990 MHz: 6 Watts CW (Max)
	2400-2500 MHz: 1 Watt CW (Max)
	4800-5900 MHz: 1 Watt CW (Max)

Mechanical

Weight	4 oz.
Height	1.18 in.
Length	3.25 in.
Width	1.38 in.
Finish	Blue Paint per Fed-Std-595 #25109
Material	6061-T6 Aluminum Alloy
Connector	(2) TNC Female (1) TNC Male

Environmental

Temperature	-55°C (-67°F) to +85°C (+185°F)
Altitude	50,000 ft.



A HEICO COMPANY

Website: www.sensorantennas.com

Phone: 818-341-5366