

ELT S65-8282-406



Description

S65-8282-406: ELT antenna covers distress signal frequencies of 121.5, 243.0 and 406 MHz.

The antenna is compatible with Cospas-Sarsat and all ELT systems. Meets requirements of EUROCAE ED-62 for ELT equipment.

Fiberglass composite blade with machined aluminum base and BNC female connector. Designed for high-speed aircraft.

NSN: 5985-01-570-3767

FEDERAL & MILITARY SPECS: MIL-E-5400, MIL-E-5272, MIL-A-7772, MIL-A-6271, MIL-A-9094, ED-62, ED-14C, TSO-C91a, TSO-C126, ETSO-2C91a, ETSO-2C126, DO-160C/D

Specifications

Electrical

Frequency	121.5 Mhz 243.0 Mhz 406.0 Mhz
VSWR	≤2.0:1 (121.5 Mhz) ≤2.3:1 (243.0 Mhz) ≤1.5:1 (406.0 Mhz)
Pattern	Omnidirectional in Azimuth Cosinusoidal in Elevation
Polarization	Vertical
Impedance	50 Ω
Power	250 mW (121.5 Mhz) 250 mW (243.0 Mhz) 5 Watts (406.0 Mhz)
Lightning Protection	DC Grounded

Mechanical

Weight	1.2 lbs. (.544 kg)
Height	9.81 in. (249.2 mm)
Width	2.42 in. (61.5 mm)
Length	8.50 in. (216 mm)
Material	6061-T6 Aluminum fiberglass
Finish	Skydrol-resistant polyurethane
Connector	BNC Female
Drag	0.6 lbs. Mach .85 @ 35,000 ft.

Environmental

Temperature	-54°C (-65°F) to +71°C (+160°F)
Altitude	60,000 ft.

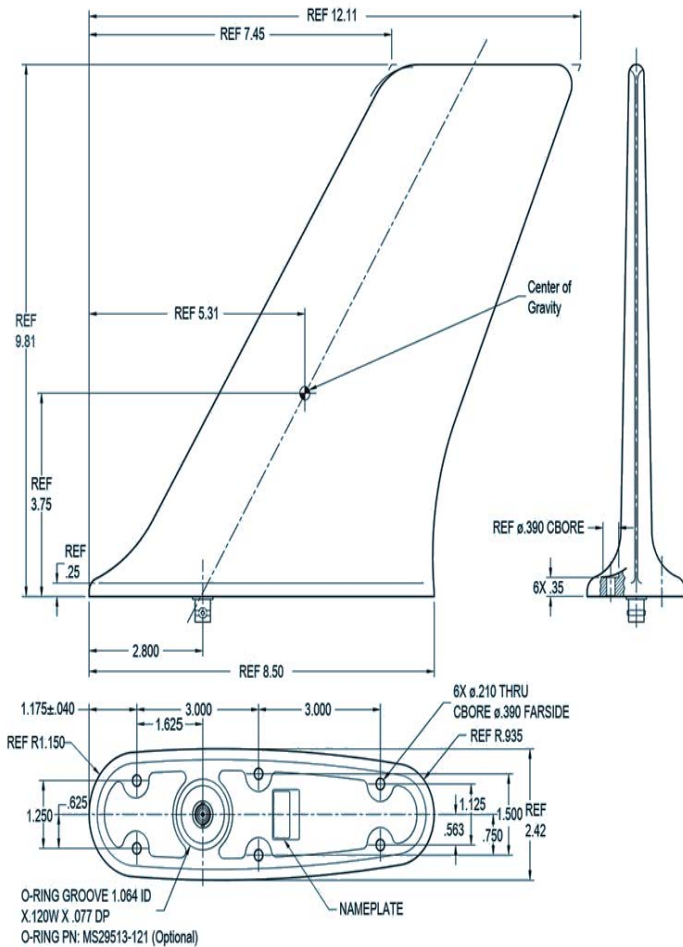

Please Note: For REFERENCE ONLY
Contact Sensor Systems for latest drawing



A HEICO COMPANY

Website: www.sensorantennas.com

Phone: 818-341-5366