

# L-Band S65-5366-2L

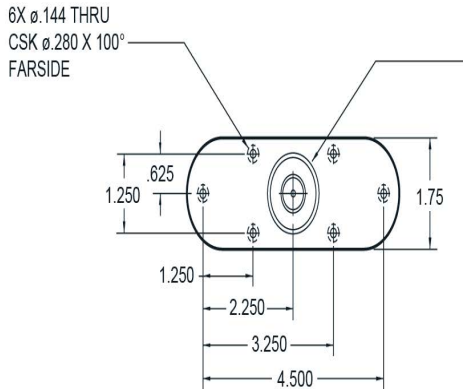
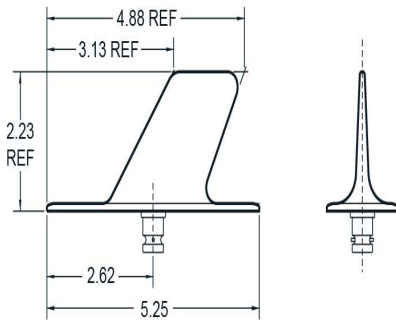

Please Note: For REFERENCE ONLY  
Contact Sensor Systems for latest drawing

## Description

**S65-5366-2L:** Rugged and highly efficient L-Band antenna to be used with DME, ATC, IFF, TACAN and MODE-S applications. The antenna is constructed from an all-metal aluminum casting with a 4-hole bolt pattern and a TNC connector.

The antenna is DC grounded to protect from lightning.

The antenna is ideal for commercial, military and general aviation aircraft.

**Federal & Military Certifications:** FAA TSO C66c, C74d and C112e, DO-144A, DO-160D/G, DO-181E, and DO-189, MIL-E-5272C, MIL-HDBK-5400, MIL-STD-810D and SAE ARP5416.

## Specifications

### Electrical

Frequency	960-1220 MHz
VSWR	≤1.70:1 (960-1220 MHz) ≤1.42:1 (1000-1100 MHz)
Polarization	Vertical
Pattern	Omnidirectional in Azimuth Cosinusoidal in Elevation
Impedance	50 Ω
Power	250 Watts Continuous 2500 Watts Peak

### Mechanical

Weight	4.3 oz.
Height	2.23 in.
Length	5.25 in.
Width	1.75 in.
Material	A-356 Aluminum Alloy
Finish	Skydrol Resistant Polyurethane Enamel
Connector	HN Female

### Environmental

Temperature	-55°C (-67°F) to +85°C (+185°F)
Altitude	0 to 50,000 ft.



A HEICO COMPANY

Website: [www.sensorantennas.com](http://www.sensorantennas.com)

Phone: 818-341-5366